



Shakti Udyog Limited

Plate Exposing Systems



- THERMALLY PROTECTED TRANSFORMER
- MAINTENANCE FREE VACUUM SYSTEM
- MAXIMUM EXPOSURE AREA 70X95,95X115
- LIGHT INTEGRATOR FOR EVEN EXPOSURE
- MICROPROCESSOR BASED EXPOSURE COMPUTER
- NINE PROGRAMMABLE MEMORY CHANNELS
- USER FRIENDLY FRONT PANEL
- OPERATOR SAFETY SCREEN
- OPTIONAL DIFFUSION SCREEN, STORAGE DRAWER
- AVAILBLE IN INSTANT START & SHUTTER TYPE MODELS
- FLIPTOP DUAL FRAME MODEL FOR NEWSPAPERS

METAL HALIDE PRINTING DOWN FRAMES

Shakti's printing down frame has been in the field for over one and a half decades with major newspapers and commercial customers satisfied. A wide range suited and tailored for the industry has been our speciality. Forays into Infrared and UV conveyer systems have also been successful for us.

PRINTING DOWN FRAMES

SIZES 25 X 36", 37 X 45" & 45 X 55"	
IMPORTED REFLECTORS DESIGNED FOR COLLOMATION	
VOLTAGE TAP SELECTOR	
EASY SERVICE HATCH	
SPECIAL UV SENSORS	
THERMALLY PROTECTED LAMP	
9 CHANNEL EXPOSURE COMPUTER, MICRO PROCESSOR BASED	
THERMALLY PROTECTED TRANSFORMER)	
WARRANTY FOR COMPLETE EQUIPMENT (EXCEPT LAMP)	

TECHNICAL SPECIFICATIONS

1 KW LAMP SOURCE (INSTANT)	220V, 50/60Hz, 16 Amps
3 KW LAMP SOURCE (INSTANT & SHUTTER)	3 PH, N + E, 50/60Hz, 25/16Amps
6 KW LAMP SOURCE (SHUTTER TYPE)	3 PH, N + E, 50/60Hz, 30 Amps

MODEL	DIMENSION Cms	EXPOSURE SIZE Cms	POWER REQUIREMENT	GROSS WT.
OHX /INS 4070	105x85x227	70x95	440 VAC, 50HZ, 3Ph, 6KVA	300 kg
OHX/INS 4095	125X105X227	95X115	440 VAC, 50HZ, 3Ph, 6KVA	350 kg
FTX/FTX,4070	142X97X122	70x95	440 VAC, 50HZ, 3Ph, 6KVA	400 kg
FTX/FTX,4095	142X9X122	70x95	440 VAC, 50HZ, 3Ph, 6KVA	400 kg

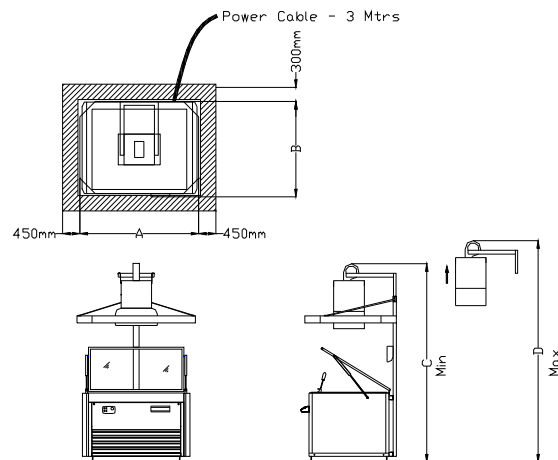

Shakti Udyog Limited
12 Second Cross Road
R.A.Puram,
Chennai – 600028
INDIA



Ph:+91-44-24343228 / 24351554
Fax; +91-44-24352148
Web: <http://www.shaktiudyog.com>
Email: mail@shaktiudyog.com