



*Shakti Udyog Limited*

# Plate Processing Systems



- 660 mm/860 mm PROCESSING WIDTHS
- DEVELOP,WASH,GUM & DRY STATIONS
- ALL OPERATIONS UNDER MICROPROCESSOR CONTROL
- PARAMETER ENTRY VIA LCD KEYPAD DISPLAY
- REWASH SLOT FOR WASH,GUM AND DRY OPERATION
- PLATE COUNT MONITOR,TEMPERATURE DISPLAY,AUTO CLEAN
- AUTOMATIC DEVELOPER REPLENISHMENT
- CHILLER UNIT FOR DEVELOPER TEMPERATURE CONTROL
- USER FRIENDLY FRONT PANEL

## CONVENTIONAL OFFSET PLATE PROCESSOR

The conventional plate processor is a rugged completely automatic machine for both positive and negative offset plates. A unique worm & worm wheel drive system is precise and self lubricating. The plate processor is provided with a rewash slot for finishing and drying. It helps preserving the plate for future jobs and also deletion. The front panel has an easy to use microprocessor with LCD display.

### FEATURES

DIP TANK PROCESS

AUTOMATIC REPLENISHMENT

ON LINE SPEED CONTROL

PLATE THICKNESS 0.15-0.4 mm

RE WASH SLOT FOR GUM & DRY

WORM & WORM WHEEL DRIVE

LCD DISPLAY WITH MESSAGES IN ENGLISH

+VE AND -VE PLATES PROCESSABLE

RE-SIRCULATION FOR DEVELOPER

ANTICORROSIVE POLYPROPELENE TANK

AUTOMATIC MACHINE CLEAN

BRUSH FOR PLATE WASH

APPLICATOR ROLLER FOR GUM

MODEL	DIMENSION mms	PROCESSING WIDTH mms	POWER REQUIREMENT	GROSS WT.
DPX 660	2600X1270X1190	660	220 V, 50/60HZ, 3KW	275 kg
DPX 860	2600X1470X1190	860	220V, 50/60HZ, 3KW	300 kg

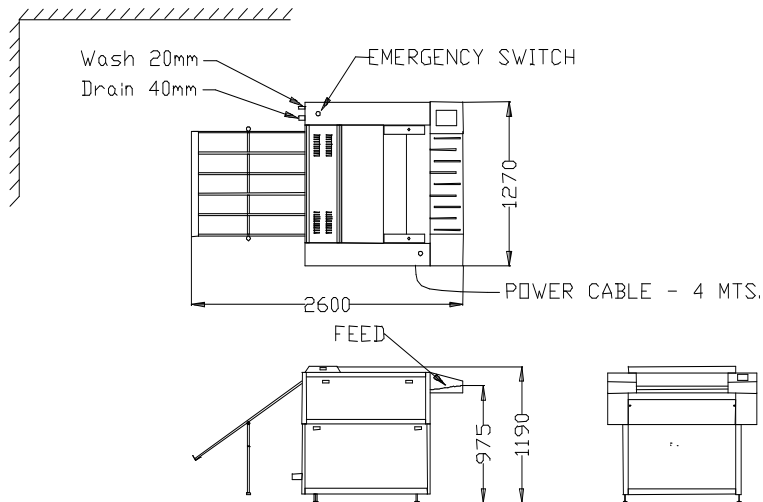

Shakti Udyog Limited  
12 Second Cross Road  
R.A.Puram,  
Chennai - 600028

Ph:+91-44-24343228 / 24351554  
Fax: +91-44-24352148  
Web: <http://www.shaktiudyog.com>  
Email: [mail@shaktiudyog.com](mailto:mail@shaktiudyog.com)